

Megger[®]



DLRO10HD and DLRO10HDX

10 Amp Digital Low Resistance Ohmmeters

User Guide

This document is copyright of:

Megger Limited, Archcliffe Road, Dover, Kent CT17 9EN. ENGLAND
T +44 (0)1304 502101 F +44 (0)1304 207342 www.megger.com

Megger Limited reserves the right to alter the specification of its products from time to time without notice. Although every effort is made to ensure the accuracy of the information contained within this document it is not warranted or represented by Megger Limited to be a complete and up-to-date description.

For Patent information about this instrument refer to the following web site:
megger.com/patents

This manual supersedes all previous issues of this manual. Please ensure that you are using the most recent issue of this document. Destroy any copies that are of an older issue.

Declaration of Conformity

Hereby, Megger Instruments Limited declares that radio equipment manufactured by Megger Instruments Limited described in this user guide is in compliance with Directive 2014/53/EU. Other equipment manufactured by Megger Instruments Limited described in this user guide is in compliance with Directives 2014/30/EU and 2014/35/EU where they apply.

The full text of Megger Instruments EU declarations of conformity are available at the following internet address megger.com/company/about-us/eu-dofc

Contents

1. Instrument Safety	6
1.1. Measurement Connection	7
1.2. Safety and Hazard Icons in this guide	7
1.3. Safety, Hazard and Warning symbols on the instrument	8
2. Description	8
2.1. Key Features	9
3. Applications	10
4. Overview	11
4.1. Controls and Connections on DLRC10HD	11
4.1.1. Secondary Display	11
4.2. Controls and Connections on DLRO10HDX	12
4.3. Test Mode Rotary Switch	13
4.4. Range Rotary Switch	14
4.4.1. Resolution and Accuracy	14
5. Test Leads	15
5.1. Connection to the Instrument	15
5.2. Test Lead Connection	15
5.2.1. Connection to a Test Piece	16
5.3. DH4-C Duplex Hand-spikes	16
5.4. Tests with the DH4-C Duplex Hand spikes or Individual Leads	16
6. Tests	17
6.1. Inductive Test	17
6.2. Manual Bi-directional Test	18
6.3. Automatic Bi-directional Test	19
6.4. Automatic Uni-directional Test	20
6.5. Continuous Test	21
7. Tests with Automatic Save (DLROHD10X)	22
7.1. Automatic Bi-directional Test	22
7.2. Automatic Uni-directional Test	23
7.3. Continuous Test	24
8. Memory Features (DLRO10HDX)	25
8.1. Date and Time Setup	25
8.2. Recall Test Result Records	25
8.3. Download Test Result Records	26
8.4. Delete Test Result Records	27

9. Maintenance	28
9.1. Routine Inspection	28
9.2. Cleaning	28
9.3. Instrument Care	28
9.4. Test Leads	28
9.5. Mains Power Fuse	28
9.6. Battery Care	28
9.7. Battery Charge	28
10. Specifications	29
10.1. Power Lead	30
10.1.1. Power Lead Connection Table	30
10.2. Download PowerDB	30
11. Accessories	31
12. Calibration, Repair and Warranty	32
12.1. Calibration, Service and Spare Parts	32
12.2. Approved Repair Companies	33
12.3. Return Procedure	33
13. End of Life Disposal	34
13.1. WEEE Directive	34
13.2. Batteries	34
14. Declaration of Conformity	35

1. Instrument Safety

If the equipment is used in a manner not specified by the manufacturer, the protection provided by the equipment may be impaired

- The instrument must be operated only by suitably trained and competent persons
- Users of this equipment and their employers are required by National Health and Safety Legislation to carry out valid risk assessments of all electrical work so as to identify potential sources of electrical danger and risk of electrical injury
- The instrument must NOT be used if any part of it is damaged
- Damaged test leads must NOT be used. Test leads, connectors and mechanical guards must be in good order, clean and have no broken or cracked insulation
- If the test subject to which the instrument is connected is energised while the instrument is turned off, protection devices may not prevent the instrument from overheating. In which case, parts of the case may become very hot and damage may occur
 - Set the instrument to ON before connecting to the test subject
 - The test subject must be set to OFF, de-energised and checked before test connections are made. Make sure that the test subject cannot be re-energised whilst the instrument is connected
 - Do not leave the equipment unattended when connected to the test subject
 - Do not leave the equipment connected to the test subject after the test is completed
- The user must exercise caution when connecting to and disconnecting from the test subject
 - Always connect test leads to the instrument before attaching to test subject
 - Keep hands behind any tactile barriers on probe clips and clamps when making or breaking connections.
 - High current connections between the instrument and test subject must be secured against accidental detachment and must not be disengaged whilst test current is flowing
 - Circuit terminals must not be touched during test
 - Do not disconnect the instrument from the test subject until the test current has stopped and the TEST warning indicator is extinguished
 - Test leads and connections may become hot during use. Exercise caution when handling
 - Disconnect from the test subject before switching the instrument OFF
- There are no user-serviceable parts inside the instrument; all servicing, including battery and fuse replacement, must be referred to a Megger approved service centre
- When used on hazardous voltages the Megger terminal cover (part number 1002-390) must be used
- This product is not intrinsically safe. Do not use in an explosive atmosphere

1.1. Measurement Connection

Only Megger supplied test leads designed for this instrument provide the full safety rating.

Voltage : The rated measurement connection voltage is the maximum line to earth voltage at which it is safe to connect.

CAT IV : Measurement category IV: Equipment connected between the origin of the low-voltage Mains Power supply and the distribution panel.





CAT III : Measurement category III: Equipment connected between the distribution panel and the electrical outlets.

CAT II : Measurement category II: Equipment connected between the electrical outlets and the User's equipment.

Measurement equipment may be safely connected to circuits at the marked rating or lower. The connection rating is that of the lowest rated component in the measurement circuit.









1.2. Safety and Hazard Icons in this guide

This section details the various safety and hazard icons on the instruments outer case.

Description	
DANGER : Indicates a dangerous situation which, if ignored, could lead to death, serious injury or health problems.	
WARNING : Indicates a potentially dangerous situation which, if ignored, could lead to death, serious injury or health problems.	
ATTENTION : Indicates a dangerous situation which, if ignored, could lead to injuries or health problems.	
CAUTION : indicates a situation which could lead to damage of the equipment or environment	
NOTE : Indicates important instructions to be followed to perform the relevant process safely and efficiently.	
Icon	Description
	EN ISO 7010 P007 Interference to the operation of or damage to active implanted cardiac devices from this equipment which generates strong electromagnetic fields. No access for people with active implanted cardiac devices.
	EN ISO 7010 W006 Warning of the presence of strong magnetic field.
	EN ISO 7010 W001 Warning to consult the user instructions. Caution is necessary when operating the device or control close to where this symbol is placed, or to indicate that an operation needs operator awareness and protective action in order to avoid hazardous situations.
	HIGH VOLTAGE, Risk of electric shock
	Earth/Ground

1.3. Safety, Hazard and Warning symbols on the instrument

This paragraph details the various safety and hazard icons on the instrument's outer case.

Icon	Description
	Warning: High Voltage, risk of electric shock
	Caution: Refer to user guide.
	UK conformity. This equipment complies with current UK legislation
	EU conformity. Equipment complies with current EU directives.
	Equipment complies with current 'C tick' requirements.
	Do not dispose of to landfill, sewage systems or by fire.
	Equipment protected throughout by double insulation.
	Reference earth connection. Not a protective earth terminal
	Fuse

2. Description

This User Guide details the DLRO10HD and the DLRO10HDX.

Both the DLRO10HD and the DLRO10HDX measure the same tests and parameters, in addition the DLRO10HDX can save, recall and download test results to PowerDB.

The DLRO10 range of digital low resistance ohm meters measure resistance in a range of 0.1 $\mu\Omega$ to 2 k. These instruments provide a maximum test current of 10 Amps. The DLRO10 range consist of four versions:

- DLRO10
- DLRO10X
- DLRO10HD
- DLRO10HDX

2.1. Key Features

- Simple operation
- High power ranges
- Simultaneous testing and battery charging
- Rugged case construction designed for use in demanding environments or the lab
- IP65 with the lid closed and IP54 with the lid open for protection against ingress during operation
- Multiple lead set options (Megger connect leads - see the lead set data-sheet)
- 10 A while measuring up to 250 m Ω and 1 A while measuring up to 2.5 Ω
- Monitors test lead contact, which reduces the chance of erroneous readings
- Rechargeable battery: Capacity <1000 10A test
- Auto power off
- Large, clear LCD for all light conditions
- Time and Date stamped memory for recording of results (DLRO10HDX only)
- Memory storage and USB download capability (DLRO10HDX only)
- CAT III 300 V: Protected against accidental connection to external voltages up to 600 V DC applied between any pair of the four terminals for up to 10 seconds

3. Applications

The DLRO10HD and DLRO10HDX measure low resistance values in applications ranging from railways and aircraft to resistance of components in industry.

Any metallic joint can be measured but users must be aware of measurement limitations depending on application. For example, if a cable manufacturer plans to make resistive measurements on a thin wire, a low test current should be selected to prevent heating the wire thereby changing its resistance.

Both instruments are well suited to measuring thick conductors, bonds and quality of welding because of their 10 A range for resistance values up to 250 mΩ. Measurements on electric motors and generators will be inductive and require the User to understand the inductive mode and charging process before a correct result is achieved.

Electromagnetic noise induced into the leads can interfere with a reading. A noise icon alerts the User, but does not prevent a measurement.

When dissimilar metals are joined a galvanic effect is created. Users should select a Bi-directional mode to make sure this effect is cancelled. The instrument measures with current flowing in both directions and averages the result.

Typical applications include DC resistance measurements of:

- Switch and contact breaker resistance
- Transformer and motor winding resistance
- Busbar and cable joints
- Rail and pipe bonds
- Aircraft frame bonds and static control circuits
- Metal alloys, welds and fuse resistance
- Integrity of welded joints
- Graphite electrodes and other composites
- Inter-cell connections on battery systems
- Wire and cable resistance
- 300 V peak
- Transmitter aerial and lightning conductor bonding
- Quality control of resistive components

4. Instrument Overview

4.1. Controls and Connections DLRO10HD

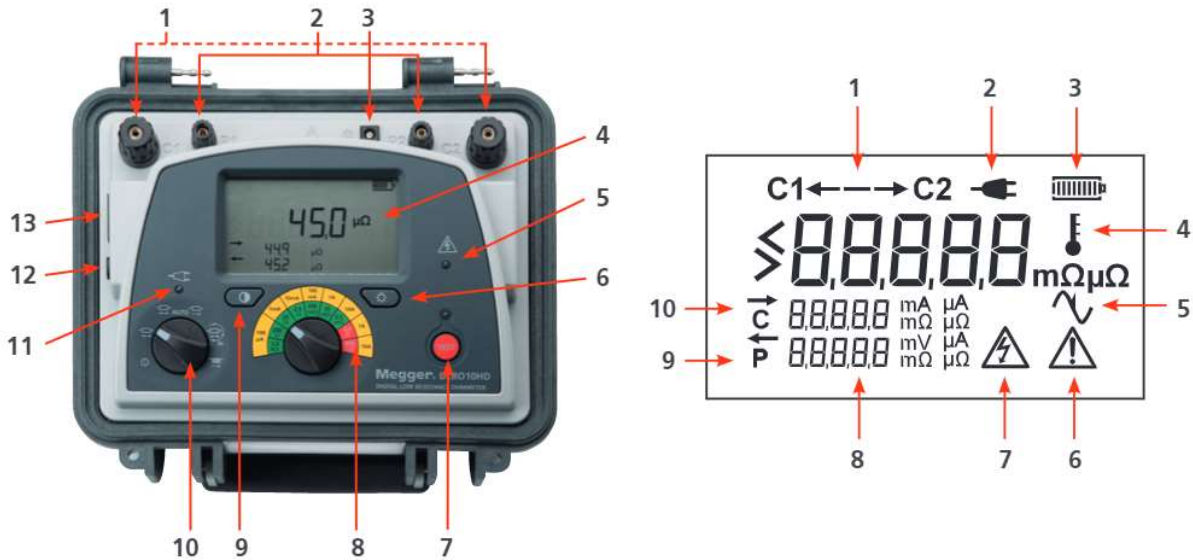

Item	Description
1	Current terminals
2	Potential terminals
3	Test lead LED cable
4	Display
5	Hazard warning LED during test
6	Back-light
7	Test button (start and stop tests)
8	Range rotary switch
9	Contrast button
10	Test modes and off rotary switch
11	Mains power on LED
12	Fuse
13	Mains power socket

Item	Description
1	Direction of current flow in a test
2	Mains power connected
3	Battery status
4	Over temperature
5	Noise (over 100 mV 50 / 60 Hz)
6	Refer to user guide
7	High voltage warning
8	Secondary display
9	Directional arrow to show current flow above P indicator
10	Directional arrow to show current flow above C indicator

4.1.1 Secondary Display



Directional arrow to show current flow above C indicator

Directional arrow to show current flow above P indicator

4.2. Controls and Connections DLRO10HDX

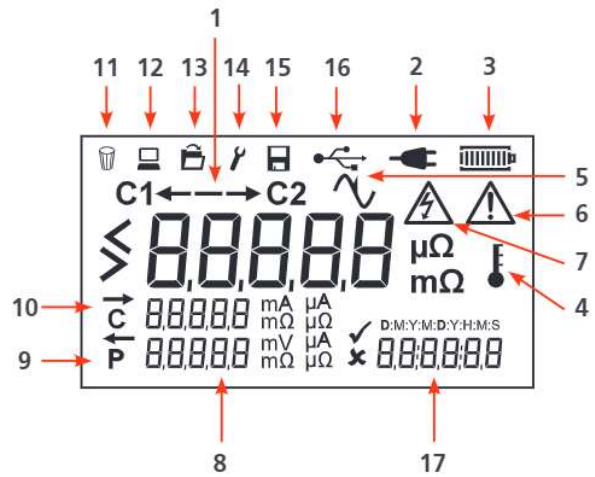

Item	Description
1	Current terminals
2	Potential terminals
3	Test lead LED cable
4	Display
5	Hazard warning LED during test
6	Back-light
7	Test button (start and stop tests)
8	Range rotary switch
9	Contrast button
10	Test modes and off rotary switch
11	Mains power on LED
12	Fuse
13	Mains power socket
14	Save Button
15	USB socket (download records)
16	Navigation keypad (setup and stored results)

Item	Description
1	Direction of Current flow in a test
2	Mains Power connected
3	Battery Status
4	Over Temperature
5	Noise (over 100 mV 50 / 60 Hz)
6	Refer to User Guide
7	High Voltage Warning
8	Secondary Display
9	Directional arrow to show current flow above P indicator
10	Directional arrow to show current flow above C indicator
11	Delete
12	Test Result Download mode
13	Recall Test Result Mode
14	Date and Time mode
15	Save mode
16	USB connected
17	Date / Time

4.3. Test Mode Rotary Switch

Test modes and instrument Off are selected with the Test Mode rotary switch.

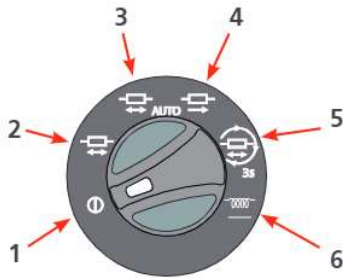

Available test modes are:

Item	Mode	Description
1	Off	Instrument is Off . Rotate the switch to any mode to start the instrument.
2	Manual Bi-directional	Test current applied in both directions current flow. Continuity of all four connections is checked. Current is applied in both forward and reverse direction. See 6.2. Manual Bi-directional Test on page 8.
3	Automatic Bi-directional	Test current applied in both directions current flow. See 6.3. Automatic Bi-directional Test on page 19: Automatic save (DLRO10HDX).
4	Automatic Uni-directional	Current is applied in one direction only, to speed up the measurement process. Standing EMF's setup during the test are ignored so lower accuracy can result. See 6.4. Automatic Uni-directional Test on page 20: Automatic save (DLRO10HDX).
5	Continuous	Test current is applied in both directions. The test repeats at three seconds intervals. See 6.5. Continuous Test on page 21: Automatic save (DLRO10HDX)
6	Inductive	Test current applied in only one direction. See 6.1. Inductive Test on page 17

WARNING : When inductive loads are measured the current carrying leads must be securely clamped to the item being tested.

WARNING : Do not remove the current carrying leads before any stored charge has been discharged at the end of the test.

WARNING : Failure to comply with these instructions might result in an arc being produced, which might be dangerous for the instrument and the operator.

NOTE : When inductive loads are measured it is necessary to wait for the voltage to stabilise, so the measurement process can take a few seconds or several minutes.

4.4. Range Rotary Switch

The instruments test range of resistance and current is selected with the Range rotary switch.

DLRO10HDX

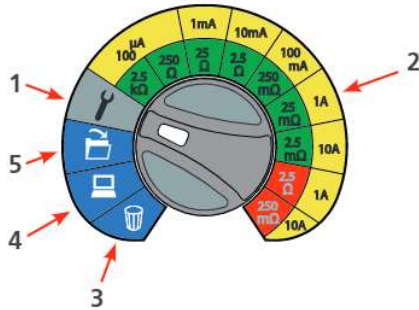

DLRO10HD

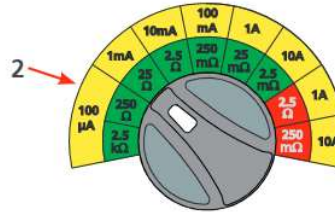

- Green resistance ranges: Low output power (<0.25 W) outputs
- Red resistance ranges: Higher 2.5 W (1 A) and 25 W (10 A) power outputs (⚠ shows)

Item	Description
1	See 8.1. Date and Time Setup on page 25
2	See 4.4.1 Resolution and Accuracy on page 14
3	See 8.4. Delete Test Result Records on page 27
4	See 8.3. Download Test Result Records on page 26
5	See 8.2. Recall Test Result Records on page 26

4.4.1 Resolution and Accuracy

- Test current accuracy ±10%
- Voltmeter input impedance >200 kΩ
- Maximum lead resistance at 10 A <100 mΩ

Test Current	Resistance Range	Resolution (as shown)	Basic Accuracy*	Full Scale Voltage	Max. Power Output
100 μA	0 to 2.5 kΩ	0.1 Ω	±0.2% ±200 mΩ	25 mV	25 μW
100 μA	0 to 250 Ω	0.01 Ω	±0.2% ±20 mΩ	25 mV	2.5 μW
1 mA	0 to 25 Ω	1 mΩ	±0.2% ±2 mΩ	25 mV	25 μW
10 mA	0 to 2.5 Ω	0.1 mΩ	±0.2% ±200 μΩ	25 mV	250 μW
100 mA	0 to 250 mΩ	0.01 mΩ	±0.2% ±20 μΩ	25 mV	2.5 mW
1 A	0 to 25 mΩ	1 μΩ	±0.2% ±2 μΩ	25 mV	25 mW
10 A	0 to 2.5 mΩ	0.1 μΩ	±0.2% ±0.2 μΩ	25 mV	0.25 W
1 A *	0 to 2.5 Ω	0.1 mΩ	±0.2% ±200 μΩ	2.5 V	2.5 W
10 A**	0 to 250 mΩ	0.01 mΩ	±0.2% ±50 μΩ	2.5 V	25 W

* Basic accuracy stated assumes forward and reverse measurements.

** Higher 2.5 W (1 A) and 25 W (10 A) power outputs (⚠ shows).

Inductive or Uni-directional mode can introduce an undefined error if an external EMF is present.

Basic accuracy at reference conditions.

5. Test Leads

The test leads can be used with either:

- Hand-spikes or
- Clamps

See 11. Accessories on page 31.

5.1. Connection to the Instrument

Connect the supplied test leads to the instrument as show below:

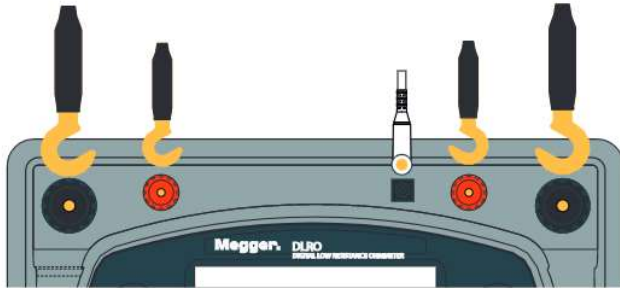

NOTE : To help connect the test leads remove the instrument lid. Open the lid to approximately 45° and slide it to the right.

5.2. Test Lead Connection

A good test measurement requires both the Current carrying circuit and the Voltage detection circuit to be completed by the unit under test. The Instrument checks for continuity in both C and P circuits.

A test will not start until there is a good connection to the test piece by the test leads.

Confirmation of successful continuity:

- If C 1----2 and P 1----2 are constant the connectivity is good
- If either C 1----2 and P 1----2 flash there is no connectivity, and the test will not start

Successful Connection	Unsuccessful connection
<pre> C 1---2 P 1---2 </pre>	<pre> \ C 1---2 / \ P 1---2 / </pre>

The resistance result is shown on the display in either Ω , m Ω or $\mu\Omega$ ranging from 2500.0 Ω to 0.1 $\mu\Omega$.

The result in Bi-directional modes is the average of two readings shown by the two secondary displays, with arrows to show the direction of current flow. The large arrow at the top of the display between C1 and C2 shows the measurement current flow.

Test Leads

5.2.1 Connection to a Test Piece

Connect the test leads to the test piece in the Kelvin arrangement as shown:

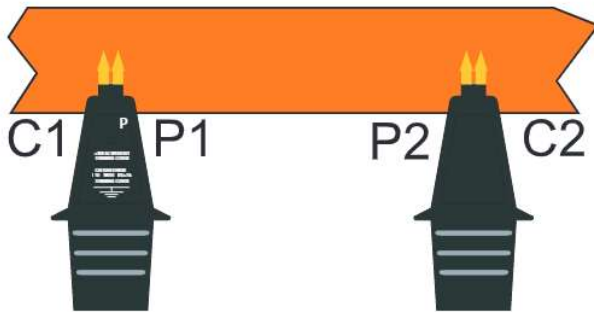

The image shows the correct test lead connection of the current (C1, C2) and potential probes (P1, P2) to a test piece. To make sure test readings are accurate, the current terminals (C1 and C2) must be connected outside of the potential terminals (P1 and P2).

5.3. DH4-C Duplex Hand-spikes

Each hand-spike is marked with the letter **P** (potential terminals). These should always be the **inside** contacts when a test measurement is taken.

One of the test lead connectors has two LEDs (**L1** and **L2**) and an LED driver cable. The LED driver cable plugs into the terminal next to terminal **P2** (see **See 5.1. Connection to the Instrument on page 15**).

LEDs **L1** and **L2**, give information to the User that would otherwise only be available on the display:

Lamp L1	Lamp L2	Description
On (red)	Off	Inadequate continuity at C or P contacts
Flashing (red)	Off	Voltage present between contacts
Off	On (green)	Current, 1mA, test complete
Off	On (red)	Measurement fail

For example, when the test leads are used in an Auto test mode:

1. Press .
2. **L1** shows a steady red to show there is a contact failure.
3. When all four contacts are connected, **L1** goes Off.
4. No LEDs show in a test, unless contact fails.
5. To signal end of test, **L2** shows a steady green when the current flow has decayed to less than 1 mA.
6. When the test leads are removed from the test piece, **L2** goes Off (end of test) and **L1** shows red (no contact).

When the DH4-C Duplex Hand-spikes are used, the instrument always makes sure that there is a good contact before the full test current is applied, so there should be no erosion of the contact tips. However, if the tips become worn or blunted, they can be replaced. Pull out the worn tips and install new ones.

5.4. Tests with the DH4-C Duplex Hand-spikes or Individual Leads

Connect the four leads as shown. In all cases make sure that the potential probes (P1 and P2) are inside the current (C1 and C2) probes.

6. Tests

This section details the instruments test procedures, which also can be manually saved (DLRO10HDX only). For information on test lead connection to a test piece, See 5.2. Test Lead Connection on page 15.

6.1. Inductive Test

WARNING : When inductive loads are measured the current carrying leads must be securely clamped to the item being tested.

WARNING : Do not remove the current carrying leads before any stored charge has been discharged at the end of the test.

WARNING : Failure to comply with these instructions might result in an arc being produced, which might be dangerous for the instrument and the operator.

NOTE : When inductive loads are measured it is necessary to wait for the voltage to stabilise, so the measurement process can take a few seconds or several minutes.

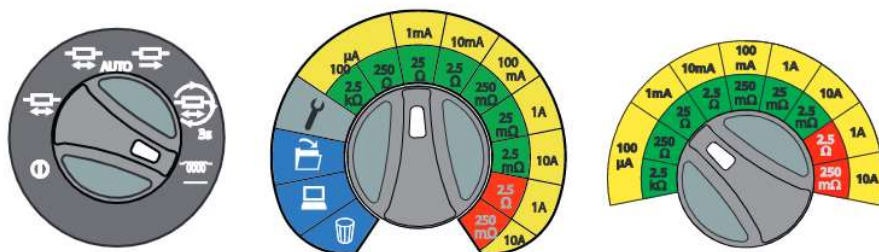

NOTE : Use Clamp test leads (optional accessory).

1. Press  .
Test starts (LED shows red).
Arrow direction animated (based on current direction) and plateau.
2. Continuous measurements are taken on the connected test piece.
The last three test records show (new test result shows on the Primary display (rolling display)).
Last test record is shown while the next test is in progress.

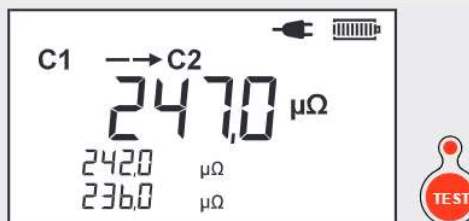

3. Press  to stop the test.
The last complete three test results are shown.



4. **DLRO10HDX only:** Save test results (if required).
Press  . The test result is saved and the memory slot number is shown.
The Save screen is shown for three seconds.



6.2. Manual Bi-directional Test



NOTE : Use Clamp test leads (optional accessory). In Manual test mode both the Current and Voltage test leads must be connected across the test piece before **TEST** is pressed.

1. Press **TEST** (acknowledged by a beep sound).
Test starts (LED shows red).

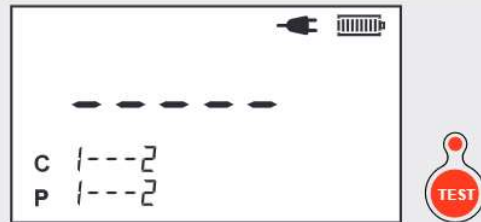

Arrow direction animated (based on current direction) and plateau.

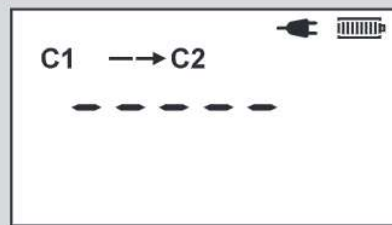

Test result for the currently connected test piece is shown.



2. **DLRO10HDX only:** Save test results (if required).

Press . The test result is saved and the memory slot number is shown.
The Save screen is shown for three seconds.



3. If the test piece is still connected, press **TEST** to do another test.

4. **DLRO10HDX only:** Press  as required.

6.3. Automatic Bi-directional Test

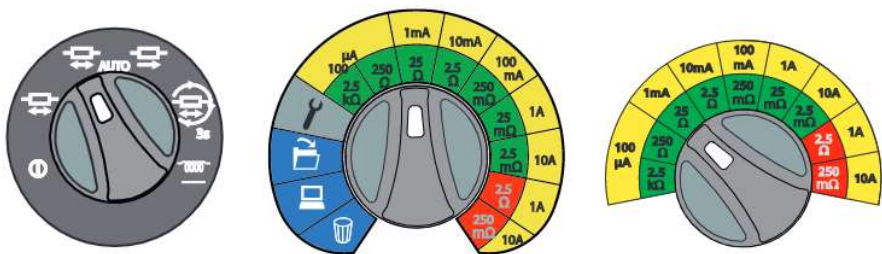

1. Connect the test leads to the test piece.
Test starts (LED shows red).

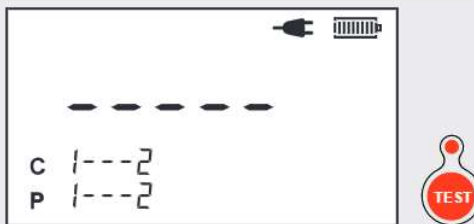

Arrow direction animated (based on current direction) and plateau.

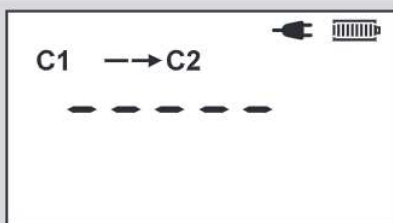

2. Test results for the currently connected test piece are shown.



3. **DLRO10HDX only:** Save test results (if required).

Press . The test result is saved and the memory slot number is shown.
The Save screen is shown for three seconds.



4. The test automatically continues for subsequent connected test piece.

5. **DLRO10HDX only:** Press  as required.

6. Press  to stop the test.

6.4. Automatic Uni-directional Test

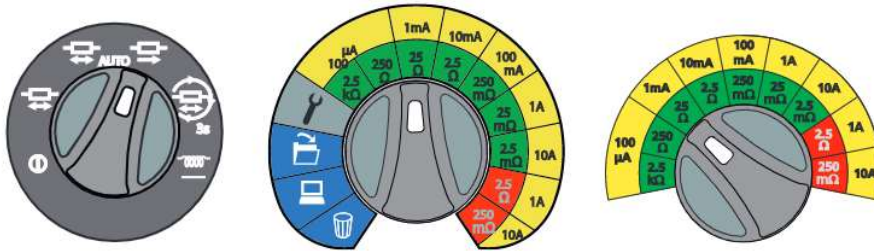

1. Connect the test leads to the test piece.
Test starts (LED shows red).

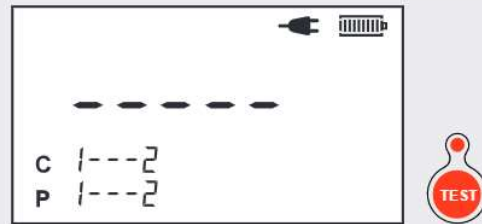

Arrow direction animated (based on current direction) and plateau.

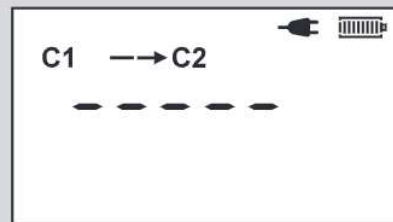

2. Test results for the currently connected test piece are shown.

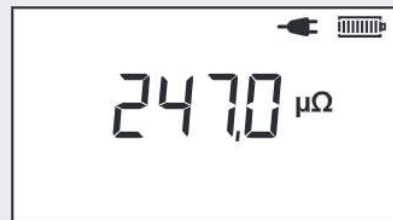

3. **DLRO10HDX only:** Save test results (if required).

Press . The test result is saved and the memory slot number is shown.
The Save screen is shown for three seconds.



4. The test automatically continues for subsequent connected test piece.

5. **DLRO10HDX only:** Press  as required.

6. Press  to stop the test.

6.5. Continuous Test

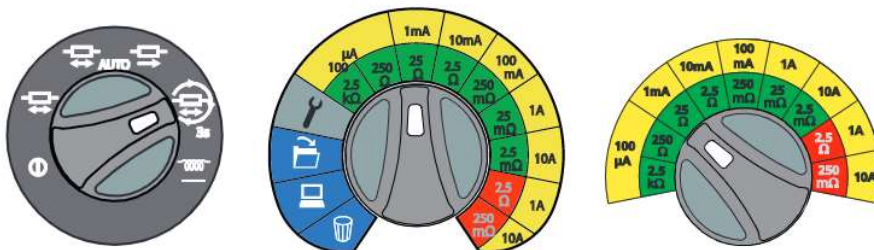

NOTE : Use Clamp test leads (optional accessory).

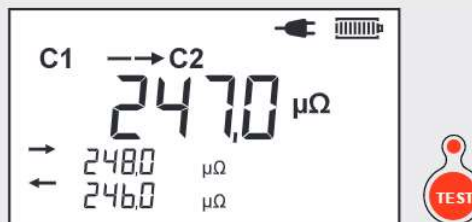

1. Press  .
Test starts (LED shows red).
Arrow direction animated (based on current direction) and plateau.





2. Continuous measurements are taken on the connected test piece.
Tests are made every three seconds.
Last test record is shown while the next test is in progress.

3. **DLROHD10X only:** Save test results (if required).
At any point press  (acknowledged by a beep sound).
Test results are saved until the test is stopped or the memory is full (2000 records).



4. Press  to stop the test.
DLROHD10X only: If  was pressed in Step 3, Test results are saved and the memory slot number is shown. The Save screen is shown for three seconds.



5. **DLROHD10X only:** If  was not pressed in Step 3, save test results if required.
Press  . The last complete test result is saved and its memory slot number is shown. The Save screen is shown for three seconds.

7. Tests with Automatic Save (DLROHD10X)

This section details the instruments test procedures, which can be automatically saved.

For information on test lead connection to a test piece, see **See 5.2. Test Lead Connection on page 15.**

7.1. Automatic Bi-directional Test

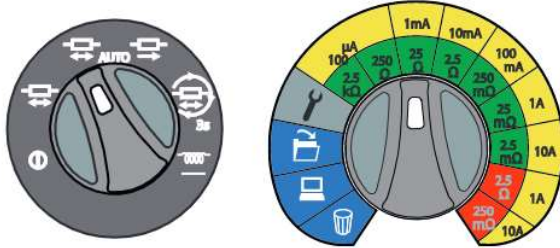

1. Press  (acknowledged by a beep sound).
Save function is available until the memory has 200 test records.

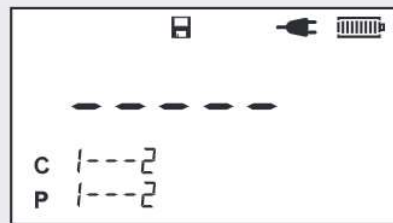

2. Connect the test leads to the test piece.
Test starts (LED shows red).
Arrow direction animated (based on current direction) and plateau.

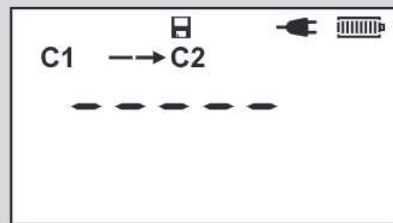

3. Test results for the currently connected test piece are shown.





Test results are saved and their memory slot number is shown. The Save screen is shown for three seconds.

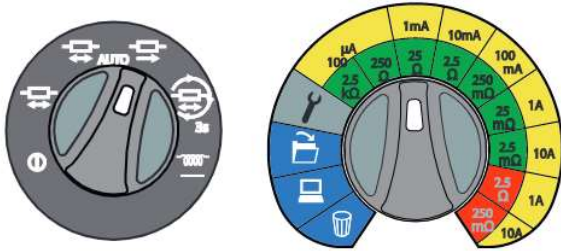

4. The test automatically continues for the next connected test piece.
5. Press  to stop the test.

7.2. Automatic Uni-directional Test



1. Press  (acknowledged by a beep sound).
Save is available until the memory has 200 test records.

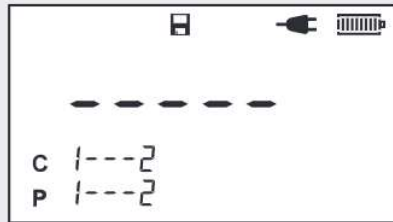

2. Connect the test leads to the test piece.
Test starts (LED shows red).
Arrow direction animated (based on current direction) and plateau.

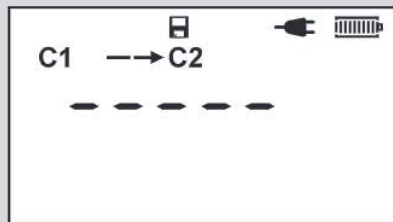

3. Test results for the currently connected test piece are shown.
4. Test results are saved and their memory slot number is shown. The Save screen is shown for three seconds.



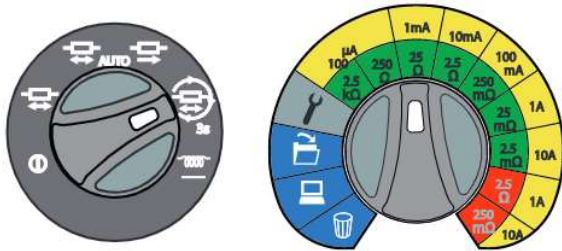

5. The test automatically continues for the next connected test piece.
6. Press  to stop the test.

7.3. Continuous Test



NOTE : Use Clamp test leads (optional accessory). See 11. Accessories on page 31

1. Press  (acknowledged by a beep sound).
Save is available until the memory has 200 test records.
2. Press . Test starts (LED shows red).

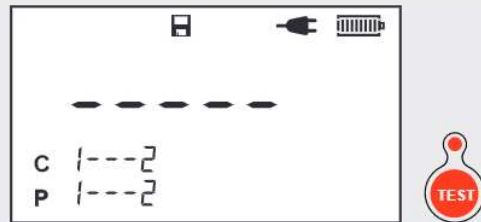

3. Arrow direction animated (based on current direction) and plateau.
4. Continuous measurements are taken on the connected test piece.
Tests are made every three seconds.
Last test record is shown while the next test is in progress.



5. Press  to stop the test.
Test results are saved and their memory slot number is shown. The Save screen is shown for three seconds.



8. Memory Features (DLRO10HDX)

The DLRO10HDX can record, saved and download test results, complete with a date and time stamp. Up to 200 memory slots are available.

8.1. Date and Time Setup

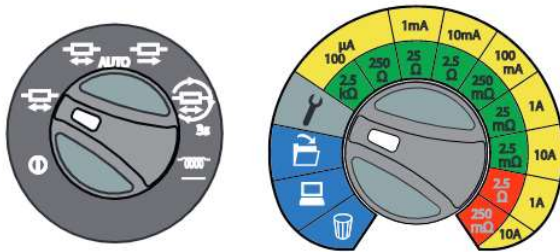

To Set Date and Time

■ Press  to toggle between D:M:Y or M:D:Y format (Default: DMY).

■ Press  to toggle between Date and Time.



1. Press  to start adjustment.

2. Press  to toggle between D/M/Y and H:M.

3. Press  to adjust.

4. Press  to scroll.

5. Press  to set.





8.4. Delete Test Result Records

All test result records or a single test result record (last recorded test result) can be deleted.

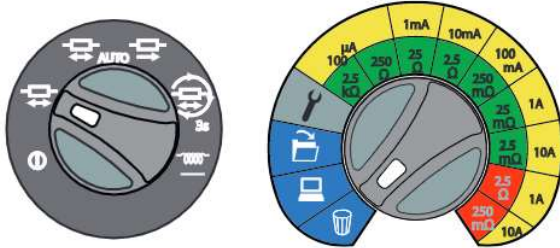

NOTE : If no records are found rEC and  show on the display.

 flashes to show Memory Delete mode.



1. Press  to toggle **SLOt** (Single delete) or **ALL** (Delete All).
Single Delete: Only the last test record in the list can be deleted, at a time.



2. Press  to confirm deletion ( shows constant to confirm delete mode).



3. Press  to delete.

9. Maintenance

9.1. Routine Inspection

Look for any cracks or other damage to the enclosure, missing ports, etc.

9.2. Cleaning

Disconnect the instrument from the Mains Power. Wipe it with a clean cloth slightly dampened with water or Isopropyl alcohol (IPA). Care should be taken near the terminals, the IEC Mains Power and USB sockets.

Allow the instrument to dry completely before it is used.

9.3. Instrument Care

The instrument should always be handled with care and not dropped. Always make sure that the instrument is secured when being transported to prevent mechanical shock.

9.4. Test Leads

Leads are silicone insulated and work well in all weather conditions. Always keep the leads in a suitable lead bag when in storage or transportation.

Regular inspection of leads is recommended to make sure that they are not damaged in any way. Damaged leads could affect resistance readings and are a safety hazard.

9.5. Mains Power Fuse

Always use the correct rated fuse (See 10. Specifications on page 29).

9.6. Battery Care

CAUTION : Batteries are only to be installed or removed by an Authorised Service Centre. Do not attempt to remove the batteries from this instrument.

- To prevent deep battery discharge, the battery should be charged at a minimum of three month intervals
- Never attempt to charge the battery below 0 °C (32°F) or above 40 °C (104 °F) ambient
- To improve battery life, store the instrument in a cool, dry location

9.7. Battery Charge

The battery is charged when Mains Power is connected (unless a test is in progress).

For optimum battery life, charge the battery after each use. A fully discharged battery takes eight hours to recharge.

The charge level will go from low to full charge in incremental steps and continue as long as Mains Power is connected (unless a test is in progress). When the battery is fully charged the battery icon will stay steady.



Battery full charge



Battery charge low



Battery discharged: The instrument shuts down automatically.

10. Specifications

Item	Description
Temperature coefficient	< 0.01% per °C, from 5 °C to 40 °C (41 °F to 104 °F)
Maximum altitude	2000 m (6562 ft) to full safety specifications
Display size and type	Primary five digit and two five digit secondary displays
Supply rating	100 to 240 V 50 / 60 Hz 90 VA
Mains power input fuse	T 1.25 A, 250 V, HBC ceramic 20 mm x 5 mm
Battery type	6 V, 7 Ah sealed lead acid (return instrument to a Megger authorised repair agent for replacement) Lithium ion coin cell (DLRO10HDX)
Battery charge time	8 hours
Battery life	>1000 Automatic (three seconds) tests
Back-light	LED
Auto power down	300 seconds after inactivity
Mode selection	Rotary switch
Range selection	Rotary switch
Memory features	Rotary switch (DLRO10HDX only)
Memory storage	200 test result records (DLRO10HDX only)
USB connection	Download test results (DLRO10HDX only)
Weight	6.7 kg (14.8 lb)
Case dimensions	315 x 285 x 181 mm (12.4 x 11.2 x 7.1 in)
Pouch for test leads	Yes (lid mounted)
Test leads	Dependant on order code selected
IP rating	IP65 case closed IP54 battery operation
Safety rating	In accordance with IEC61010-1 CATIII 300 V when used with optional terminal cover (See 11. Accessories on page 31)
Application	IEC 61010 defines measurement categories from I to IV relating transient over voltages and the location within electrical installations. Designed for use at Category III (Building installation level) on 300 V phase to earth systems, 520 V phase to phase
Operating temperature and humidity	-10 °C to 50 °C (14 °F to 122 °F) <90% RH
Storage temperature and humidity	-25 °C to 60 °C, <90%RH
Reference conditions	20 °C (68 °F) (±3 °C / 5.4°F)
EMC	In accordance with IEC61326-1 (Heavy industrial)
Noise rejection	Less than 1% (±20) digits additional error with 100 mV peak 50 / 60 Hz. on the potential leads.  will show if hum or noise exceeds this level
Maximum lead resistance	100 mΩ total for 10 A operation irrespective of battery condition

Specifications

10.1. Power Lead

If the power lead supplied is not suitable for your Mains Power connection, do not use an adaptor. Always use a power lead installed with the correct plug. The instrument has a two-pin IEC60320 Mains Power socket.

Most power leads are made with three-core cable, so the ground connection will not be used.

10.1.1 Power Lead Connection Table

Connection	K / International	USA
Earth / Ground	Yellow / Green	Green
Neutral	Blue	White
Live (Line)	Brown	Black

If a fused plug is used, make sure that it is installed with a 3 A fuse.

The instrument can be powered from 100 – 240 V 50 / 60 Hz 90 VA.

10.2. Download PowerDB

You can now download direct from the Megger website to ensure that you have the most recent version available.

Visit megger.com/powerdb

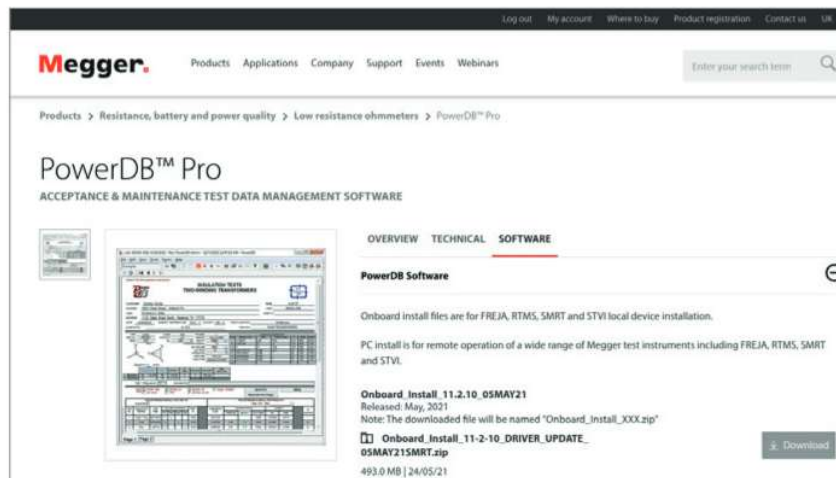

The latest edition will be at the top. Click the "download" button beside the file.

This will ask if you want to open or save the file. By clicking "Save" you will begin to download the installation package.

Then just follow the onscreen instructions to complete installation.



11. Accessories

ORDERING DLRO10HD

Item (Qty)	Order No.	Item (Qty)	Order No.
DLRO10HD + DH4-C probe 1.5m leads*	1006-603	DLRO10HD no test leads supplied*	1006-657
DLRO10HD + KC1 kelvin clip 3m leads*	1006-604	*US NEMA, UK BS 1363 and EU SCHUKO mains leads included	

ORDERING DLRO10HDX

Item (Qty)	Order No.	Item (Qty)	Order No.
DLRO10HDX + DH4-C probe 1.5m leads	1008-069	DLRO10HDX + KC1-C (2x Connect Kelvin clip 3m test leads (UK BS1363 mains lead)	1008-013
DLRO10HDX + KC1 kelvin clip 3m leads	1008-093	DLRO10HDX + KC1-C (2x Connect Kelvin clip 3m test leads (EU SCHUKO mains lead)	1008-094
DLRO10HDX no test leads (UK BS1363 mains lead)	1008-046	DLRO10HDX + KC1-C (2x Connect Kelvin clip 3m test leads (US NEMA mains lead)	1008-095
DLRO10HDX no test leads (EU SCHUKO mains lead)	1008-047	Other mains lead types are available. Please contact your local sales office or visit megger.com/support/distributors for information.	
DLRO10HDX no test leads (US NEMA mains lead)	1008-052		
DLRO10HDX + DH4-C (2x Connect Duplex handspikes 1.5m test leads (UK BS1363 mains lead)	1008-069		
DLRO10HDX + DH4-C (2x Connect Duplex handspikes 1.5m test leads (EU SCHUKO mains lead)	1008-070		
DLRO10HDX + DH4-C (2x Connect Duplex handspikes 1.5m test leads (US NEMA mains lead)	1008-075		

OPTIONAL MAINS LEADS (DLRO10HDX ONLY)

Item (Qty)	Order No.	Item (Qty)	Order No.
(CH) Swiss Mains Plug	1013-843	(IT) Italian mains plug IEC320	1013-844
(AUS/NZ) Australian/New Zealand Mains Plug	1009-623	(IN) Indian BS546 Mains Plug	1014-309

ACCESSORIES ORDERING INFORMATION

Item (Qty)	Order No.	Item (Qty)	Order No.
Terminal cover (use in conjunction with DH4 test leads supplied as standard, or optional DH5 test leads for CAT III 300 V compliance)	1002-390	Extension leads for use with Connect leads without light	1006-460
DLRO10HD and DLRO10HDX CAT III rated industrial application lead kit with terminal cover	1011-376	KL1-C Kelvin clip lead sets (3m)	1006-462
CP1-C Concentric Duplex connect probe	1006-448	KC1-C Heavy duty Kelvin clip	1006-447
DH1-C Duplex connect handspike lead set (3m)	1006-442	KC2-C Insulated connect kelvin clip	1006-451
DH4-C Duplex connect handspike lead set (1.5m)	1006-444	KC100 series test leads (1x100m/1x5m)	1000-809
DH5-C Duplex connect probe (3m)	1006-445	For detailed information on our range of test leads and comparisons, refer to data sheet DLRO test leads fitted with duplex connector . For more details visit www.megger.co...	
DP1-C Duplex connect probe (3m)	1006-450		
DTP-C Duplex connect twist probe	1006-449		
TL1.5-CL Duplex connect leads (1.5m)	1006-456		
TL3-CL Duplex connect leads (3m)	1006-458		
TL6-CL Duplex connect leads (6m)	1006-459		

12. Calibration, Repair and Warranty

Megger operate fully traceable calibration and repair facilities to make sure your instrument continues to provide the high standard of performance and workmanship that is expected. These facilities are complemented by a worldwide network of approved repair and calibration companies, which offer excellent in-service care for your Megger products.

For service requirements for Megger instruments contact:

<p>Megger Limited Archcliffe Road Dover Kent CT17 9EN U.K. Tel: +44 (0) 1304 502 243 Fax: +44 (0) 1304 207 342</p>	OR	<p>Megger Valley Forge Corporate Centre 2621 Van Buren Avenue Norristown PA 19403 U.S.A. Tel: +1 610 676 8579 Fax: +1 610 676 8625</p>
--	----	--

If the protection of an instrument has been impaired it should not be used, but sent for repair by suitably trained and qualified personnel. The protection is likely to be impaired if, for example, the instrument shows visible damage, fails to perform the intended measurements, has been subjected to prolonged storage under unfavourable conditions, or has been exposed to severe transport stresses.

New instruments are covered by a two year warranty from the date of purchase by the User, the second year being conditional on the free registration of the product on www.megger.com. You will need to log in, or first register and then login to register your product. The second year warranty covers faults, but not recalibration of the instrument which is only warranted for one year. Any unauthorised prior repair or adjustment will automatically invalidate the warranty.

These products contain no User repairable parts and if defective should be returned to your supplier in original packaging or packed so that it is protected from damage during transit. Damage in transit is not covered by this warranty and replacement / repair is chargeable.

Megger warrants this instrument to be free from defects in materials and workmanship, where the equipment is used for its proper purpose. The warranty is limited to making good this instrument (which shall be returned intact, carriage paid, and on examination shall disclose to their satisfaction to have been defective as claimed). Any unauthorised prior repair or adjustment will invalidate the warranty. Misuse of the instrument, from connection to excessive voltages, fitting incorrect fuses, or by other misuse is excluded from the warranty. The instrument calibration is warranted for one year.

This Warranty does not affect your statutory rights under any applicable law in force, or your contractual rights arising from a sale and purchase contract for the product. You may assert your rights at your sole discretion.

12.1. Calibration, Service and Spare Parts

For service requirements for Megger Instruments contact **Megger** or your local distributor or authorised repair centre.

Megger operates fully traceable calibration and repair facilities, to make sure your instrument continues to provide the high standard of performance and workmanship you expect. These facilities are complemented by a worldwide network of approved repair and calibration companies to offer excellent in-service care for your Megger products.

See the **last page** of this User Guide for Megger contact details.

To find your local Authorised Service Centre email Megger on ukrepairs@megger.com and give details of your location.

12.2. Approved Repair Companies

A number of independent instrument repair companies have been approved to do repair work on most Megger instruments, complete with genuine Megger spare parts.

Consult the Appointed Distributor / Agent about spare parts, repair facilities and advice.

12.3. Return procedure

WARNING : Remove the battery cells before shipping this instrument.

UK and USA Service Centres

- .. When an instrument requires recalibration, or in the event of a repair being necessary, a Returns Authorisation (RA) number must first be obtained from one of the addresses shown above. The following information is to be provided to enable the Service Department to prepare in advance for receipt of your instrument and to provide the best possible service to you:
 - Model (for example, MFT2100).
 - Serial number (found on the display under settings, device information, or on the rear cover and by the batteries or on the calibration certificate).
 - Reason for return (for example, calibration required, or repair).
 - Details of the fault if the instrument is to be repaired.
2. Make a note of the RA number. A returns label can be emailed or faxed to you, if required.
3. Pack the instrument carefully to prevent damage in transit.
4. Before the instrument is sent to Megger, freight paid, make sure that the returns label is attached or that the RA number is clearly marked on the outside of the package and on any correspondence. Copies of the original purchase invoice and packing note should be sent simultaneously by airmail to expedite clearance through customs. In the case of instruments which require repair outside the warranty period, an immediate quotation can be provided when obtaining the RA number.
5. Track the progress online at www.megger.com.

13. End of Life Disposal

13.1. WEEE Directive



The crossed out wheeled bin symbol placed on Megger products is a reminder not to dispose of the product at the end of its life to landfill, sewage systems or by fire.

Megger is registered in the UK as a Producer of Electrical and Electronic Equipment.
The Registration No is WEE/ HE0146QT.

For further information about disposal of the product consult your local Megger company or distributor or visit www.megger.com.

13.2. Batteries

Battery replacement **must only be done** by a Megger authorised repair agent, who will correctly dispose of the 'end of life' battery or batteries.



■ The crossed out wheeled bin icon placed on the batteries is a reminder that the batteries must not be disposed of to landfill, sewage systems or by fire.

This instrument contains:

- One sealed lead acid battery (classified as a Portable Battery), and
- One Lithium ion coin cell battery (classified as an Industrial Battery (DLRO10HDX only))

See 10. Specifications on page 29 for battery specifications.

For disposal of batteries in other parts of the EU contact your local Megger branch or distributor.

Megger is registered in the UK as a producer of batteries (Registration No.: BPRN00142).

For further information see www.megger.com

14. Declaration of Conformity

Hereby, Megger Instruments Limited declares that radio equipment manufactured by Megger Instruments Limited described in this User Guide is in compliance with Directive 2014/53/EU. Other equipment manufactured by Megger Instruments Limited described in this User Guide is in compliance with Directives 2014/30/EU and 2014/35/EU where they apply.

The full text of Megger Instruments EU declarations of conformity are available on our website:
megger.com/eu-dofc.

Local Sales office

Megger Limited
Archcliffe Road
Dover
Kent
CT17 9EN
ENGLAND
T. +44 (0)1 304 502101
F. +44 (0)1 304 207342

Manufacturing sites

Megger Limited
Archcliffe Road
Dover
Kent
CT17 9EN
ENGLAND
T. +44 (0)1 304 502101
F. +44 (0)1 304 207342

Megger GmbH
WeststraÙ 59
52074 Aachen
T. +49 (0) 241 91300 500
E. info@megger.de

Megger USA - Valley Forge
Valley Forge Corporate Center
2621 Var. Buren Avenue
Norristown
Pennsylvania 19403
USA
T. +1 610 676 8500
F. +1 610 676 8610

Megger USA - Dallas
4545 West Davis Street
Dallas TX 75237
USA
T. 800 723 2861 (USA only)
T. +1 214 333 3201
F. +1 214 331 7399
E. USSales@megger.com

Megger AB
Rinkebyvägen 19, Box 724,
SE-182 17
DANDERYD
T. +46 08 510 195 00
E. seinfo@megger.com

Megger USA - Fort Collins
4812 McMurry Avenue
Suite 100
Fort Collins CO 80525
USA
T. +1 970 282 1200

This instrument is manufactured in the United Kingdom.

The company reserves the right to change the specification or design without prior notice.

Megger is a registered trademark

The Bluetooth[®] word mark and logos are registered trademarks owned by Bluetooth SIG, Inc and is used under licence.