

SACE PR010/T Test Unit Annex



INDEX

1. Information about the functions of the SACE PR010/T unit (release 7.7)	3
1.1 Type of connection cables	4
1.1.1 CABLE A	4
1.1.2 CABLE B	4
1.1.3 CABLE C	4
1.1.4 CABLE D	5
1.1.5 CABLE E	5
1.2 Menu tree	5
2. SACE PR11x/PR212x/PR222x/PR223x protection relays	6
2.1 Operating mode menu	6
2.2 Test	6
2.2.1 Trip test	7
2.2.2 Manual test	7
2.2.3 Automatic test	8
2.2.4 Set/Reset Coil test	8
2.2.5 Inst test	8
2.2.6 Notes about the Relays	9
2.3 Reading	11
2.3.1 Measuring	11
2.3.2 Parameters/Configuration	11
2.3.3 Protections	12
2.3.4 Trip history	12
2.3.5 General information	12
2.4 Programming	12
2.4.1 Configurations	13
2.4.2 Protections	13

3.	SACE PR12x/PR232/PR33x/PR12xDC protection relays	14
3.1	Mechanical connection	14
3.2	Operating mode menu	15
3.3	Test	15
3.3.1	Automatic Test	16
3.3.2	Manual Test	16
3.3.3	Trip test	17
3.3.4	Module Test	17
3.3.5	S and G selectivity	17
3.3.6	RC Test	17
3.4	Measuring	18
3.5	Histories	19
3.5.1	Trips	19
3.5.2	Events	19
3.5.3	Statistics	19
3.6	Configurations	20
3.6.1	Circuit-breaker	21
3.6.2	Alive LED	21
3.6.3	Modules	22
3.6.4	Local Bus unit	22
3.6.5	System	23
3.7	Parameters	23
3.7.1	Limitations	24
3.8	Information	25
3.8.1	Download	25
3.9	Status	26
3.10	Installation	26
3.10.1	Disinstallation	26
3.10.2	Installation	26
3.11	Automatic Test: full description	27
3.11.1	PR121/P, PR331/P; PR122/P and PR332/P without measuring module	27
3.11.2	PR122/P and PR332/P (with measuring module)	27
3.11.3	PR123/P and PR333/P	28
3.11.4	PR232/P and PR232/P-T8	28
3.11.5	PR122/DC	29
3.11.6	PR123/DC	29

1. Information about the functions of the SACE PR010/T unit (release 7.7)

The SACE PR010/T unit can be connected to different types of ABB SACE electronic relays (also known as DUT) in order to perform tests, program and read parameters.

Using a cable and adapters, the PR010/T unit can be connected to the test connector of the relay, installed at the front. A list of relays compatible with the PR010/T unit is given below, along with the type of cables required for the connection.

RELAY (1)	CIRCUIT-BREAKER	TYPE OF CABLE	ADAPTER
PR111	EMAX	A	X
PR111/VF	EMAX VF	A	X
PR112 (2) (4)	EMAX	A / B	X
PR113 (4)	EMAX	B	
PR212 (3)	ISOMAX	C	
PR212MP (3)	ISOMAX	C	
PR222 (4) (5)	TMAX T4-T5-T6	D	
PR222MP	TMAX T4-T5-T6	D	
PR223DS (5)	TMAX T4-T5-T6	D	
PR223EF (5)	TMAX T4-T5-T6	D	
PR232	TMAX T7	E	X
PR232-T8	TMAX T8	E	X
PR331	TMAX T7-T8 / EMAX X1	E	X
PR332	TMAX T7-T8 / EMAX X1	E	X
PR333	EMAX X1	E	X
PR121	NEW EMAX	E	
PR122	NEW EMAX	E	
PR123	NEW EMAX	E	
PR122DC	EMAX DC	E	
PR123DC	EMAX DC	E	

NOTES

- 1 In all IEC and UL releases available, unless there is an additional note
- 2 Consult the details in the next chapter for connection to PR112
- 3 Connection only available for versions with a front test connector
- 4 Auxiliary voltage must be available for the PD relay versions
- 5 When the PR010T unit is connected, a relay normally connected to an external system temporarily interrupts the communication with this latter

1.1 Type of connection cables

The diagrams below illustrate examples of the types of cables available for connecting the various different relays to the PR010/T unit.

All cables are supplied as accessories of the PR010/T unit.

1.1.1 CABLE A

The diagram shows an example of connection to a PR111 relay with the aid of a mechanical adapter. Cable to be used for the IEC version of the PR112 relay with key.

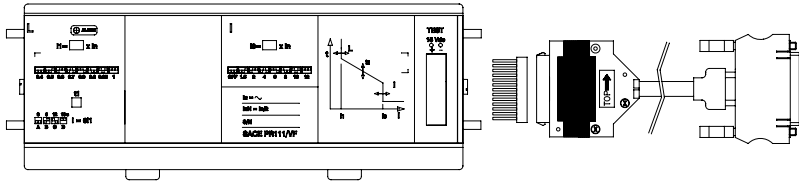

1.1.2 CABLE B

The diagram shows an example of connection to an IEC version of a PR112 relay without key. Cable to be used for the IEC version of the PR112 relay without key and for the UL version of the PR112 relay.

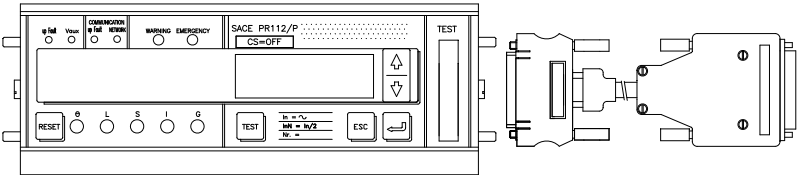

1.1.3 CABLE C

The diagram shows an example of connection to a PR212/MP relay (only for the version with front connector).

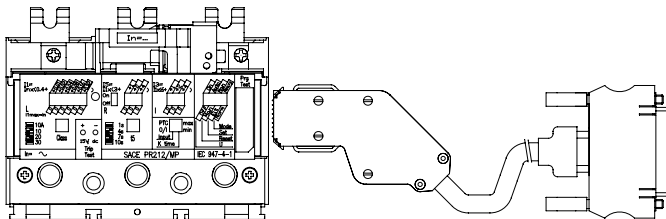

1.1.4 CABLE D

The diagram shows an example of connection to a PR223EF relay.

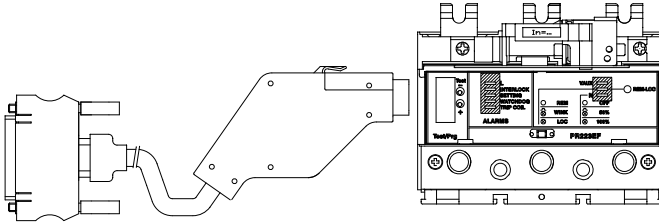

1.1.5 CABLE E

The diagram shows an example of connection to a PR331 relay with the aid of a mechanical adapter.

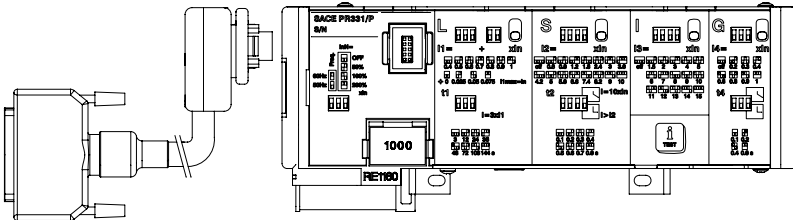

1.2 Menu tree

When connected to the SACE relay, the PR010/T relay allows all the available functions and information to be accessed by means of a tree menu.

For some of the relays, the structure of the tree menu (and the available functions and information) is very similar: they can thus be grouped into two categories, as shown in the table below:

RELAY	CIRCUIT-BREAKER	CHAPTER
PR111; PR111/VF; PR112; PR113	EMAX	3
PR212; PR212MP	ISOMAX	
PR222; PR222MP; PR223EF; PR223DS	TMAX T4-T5-T6	
PR232; PR232-T8; PR331; PR332; PR333	TMAX T7-T8 / EMAX X1	4
PR121; PR122; PR123	NEW EMAX	
PR122DC; PR123DC	EMAX DC	

2. SACE PR11x/PR212x/PR222x/PR223x protection relays

2.1 Operating mode menu

All the SACE relays belonging to this group partly or fully share certain of the functions and characteristics.

Considering the main menus, all unit can access the following menus:

- *Test*: tests of the protections, trip mechanism and high signals.
- *Reading*: monitoring of the current values, relay and circuit-breaker parameters, trip history and other information in general.
- *Programming*: editing of the relay and circuit-breaker parameters, the protection status and other configuration data.



CAUTION

During access to the menus, an error message could appear for certain of the relays, if the CB type and TA current rating have not yet been defined.

2.2 Test

The tests available with the various different SACE relays are listed in the table below.

	PR11	PR11/VF	PR112	PR113	PR212	PR212MP	PR222	PR222MP	PR223EF	PR223DS
TEST ⁽¹⁾										
Trip Test			X	X		X	X	X	X	X
Manual protections	X	X	X	X	X(2)	X(2)	X(2)	X(2)	X	X
Automatic protections	X	X	X	X	X(2)	X(2)	X(2)	X(2)	X	X
Set/reset Coil						X		X		
Inst protection	X		X	X						

NOTES

- 1 Perform the trip test with the circuit-breaker Closed and the protection test with the circuit-breaker Open.
- 2 The automatic test and manual test with the default parameters can only be performed by using the Electronic SET configuration for the relay (ELT) by means of the relative dip switch.

2.2.1 Trip test

The trip test must be performed with the circuit-breaker closed. This test allows a circuit-breaker trip command to be transmitted so as to check the operation of the relay opening system if tripping is caused by an overload or short-circuit.



2.2.2 Manual test



The manual test must be performed with the circuit-breaker open.

Two different configurations are available: test with default parameters and with user parameters:

- *Test with user parameters:* this can be performed by setting the unit in the ELT or MAN configuration. The protection parameters are at the user's discretion in this mode.
- *Test with default parameters:* this can only be performed by setting the unit in the ELT configuration. The protection parameters are preset in this mode.

In the manual test, the tripping time of the electronic relay can be tested with the desired load condition and allows the user to select the reference protection (e.g.: L, S...), the threshold and time of the protection (e.g.: I1, t1, I2, t2...), the fault current (If or I-f) and the phase (e.g.: L3, Ne...).

The  and  keys can be used to scroll the various different options available (type of protection, time settings, thresholds and curves). Press ENTER to confirm the selection.

Use keys  and  to increase/decrease the protection parameter settings and select the phase..

The tripping time of the relay will depend on the protection settings. The PR010/T unit displays the tripping time and test result (OK, FAILED).

NOTE: Reading of the protection settings is automatic for some relays while entry in the manual mode by the user is required for others.

At the end of the test, the user is asked whether a test report must be recorded. This can then be downloaded into a PC using the dedicated SD User Interface tool.



CAUTION

When the test parameters are defined, make sure that the value of the tripping current is higher than the threshold of the tested protection.



CAUTION

Make sure that the selected test current does not trip other protections besides the one being tested: these trips will be signalled as FAILED by the unit. This can be avoided by changing the threshold values of the protections and the test current.



CAUTION

The test with the default configuration is available up to version 7.5 (inclusive)

2.2.3 Automatic test

The automatic test must be performed with the circuit-breaker open.

The data acquisition channels are tested for each phase (L1, L2, L3, Ne) and the main protections of the unit are tested (e.g. trips with protections: L, S, I and G with PR212/P LSIG; L, R, I, U with PR222MP) for each relay, regardless of its functional characteristics and version..

During the various different tests, the tripping times of the relay will depend on the protection settings. The PR010/T unit displays the threshold and time of the protection in question, as well as the test result (OK or FAILED).

At the end of the test, the user is asked whether a test report must be recorded. This can then be downloaded into a PC.

2.2.4 Set/Reset Coil test

Operation of the SET and RESET outputs that control the PR212/CI unit can be tested for the MP relay versions (PR212MP and PR222MP). Each test command transmits a status change signal to the PR212/CI unit.



CAUTION

Before transmitting a Set/Reset test command, make sure that the PR212/CI unit is in the opposite position, so as to check the switching function.

2.2.5 linst test

Operation of the linst protections can be tested in PR11x series relays. The PR010/T unit will display the test result (OK or FAILED).



CAUTION

Before accessing the menu, make sure that the circuit-breaker model and the setting of the dip switch on the upper side of the relay correspond. If they are misaligned, an error message will be displayed by relays PR112 and PR113, and access to the menu will be inhibited.

2.2.6 Notes about the Relays

Consider the following indications to ensure that the tests are performed correctly.

2.2.6.1 PR111 and PR111/VF

- Before any test can be performed, certain data concerning the model and size of the CB must be entered (e.g.: E1B, 800A). The Neutral setting (50% / 100%) and the version of the unit (LI, LSI, LSIg) must also be entered in certain cases.
- Enter the settings of the protections in the following way before performing the Automatic test:

Protection	Threshold	Time
L	$I1 = 0.4I_n$	$t1 = B$
S	$I2 = 3I_n$	$t2 = C; I^2t = k$
I	$I3 = 8I_n$	--
G	$I4 = 0.8I_n$ (IEC version) $I4 = 0.4I_n$ (UL version)	$t4 = B$

NOTE: the PR111/VF relay does not control protections S, G and Inst. This means that the setting of the G protection must not be considered for automatic test configuration.

- The maximum trip time tolerance is 35% for the G function.
- The minimum threshold in the Manual Test configuration is $0.6I_n$ for the G function.

2.2.6.2 PR112

- PR010/T unit compatible with all PR112 relays in the IEC version with key, 2.20 SW version or more recent and serial number after xxxxxx03x (for PR112/P units) or xxxxx05x (for the PR112/PD versions).
- Notes for the G protection function test:
 - For the automatic test, the I4 threshold setting must be $0.4I_n$ or more (if a lower value was entered, the PR010/T unit would automatically override to $0.4I_n$ during the test). The value of the test current is $2.5 \times I4$.
 - The value of the test current in the manual test is $1.5I_n$.
 - After a test with tripping on the G protection function, the protection may trip several times more during the next 2s.
- PR112 contact wear: during the PR112 test, the operation count and contact wear signal could increase after the opening command has been generated with over 10s timing. After a few tests, the wear could reach 100% of the value and lead to an EMERGENCY warning. This warning can be reset by the customer in the following way:
 - Access the READ mode and select the page containing the contact wear indication
 - Turn the key to EDIT
 - Press the “Up” and “Down” keys for at least 5s. This will reset the contact wear and operation count indication.

2.2.6.3 PR113

- The tests must be performed with the circuit-breaker open, no busbar voltage ($V=0$) (in the point where the TV for measuring the voltage of relays PR113/P and PR113/PD are installed) and with auxiliary power supplied.

2.2.6.4 PR212 and PR222

- The manual test can be performed with both the electronic SET (ELT) and manual SET (MAN). In the manual test with manual SET, the thresholds and curves are selected with the dip switches on the protection and are automatically updated on the display of the PR010/T unit, where only the phase and test current must be set.

2.2.6.5 PR212MP and PR212MP

- In the test with PR212/MP relay version 1 (data item read automatically by the PR010/T unit), the maximum test current is 7.3In. For this reason, the automatic test will test the protection functions in accordance with the indications given above and using this value as the limit.
- The manual test can be performed with both the electronic SET (ELT) and manual SET (MAN). In the manual test with manual SET, the thresholds and curves are selected with the dip switches on the protection and are automatically updated on the display of the PR010/T unit, where only the phase and test current must be set.
- If there is no PTC for protection against overtemperatures, the “Input” dip-switch must be set as a generic input (Input = 0/1) during the test.
- The “Welded contacts” input (WC) setting must be 0 V (no alarm) during the test.
- At the end of each test, the PR010/T unit will wait until the thermal memory has reset before proceeding with any further tests so as to prevent tripping overlaps between the tested function and the overload function (L).
- Before testing the rotor blocked protection function (R), the PR010/T waits an initial time linked to the class setting of protection function L (lasting 24s at most).

2.2.6.6 PR223EF

- If the default settings are used, the front Interlocking LEDs will come on when the relays are powered with the PR010/T unit. The protection and configuration settings can be changed to suit the installation requirements.
- The EF protection must be de-activated beforehand in SW versions prior to 4.00, otherwise the test result will be negative.

2.3 Reading

The data available in the Reading mode with the various different SACE relays is given in the table below.

	PR111	PR111/VF	PR112	PR113	PR212	PR212MP	PR222	PR222MP	PR223EF	PR223DS
READING										
Current measuring			X	X	X	X	X	X	X	X
Other measurements				X ⁽¹⁾		X ⁽²⁾	X	X ⁽²⁾	X ⁽³⁾	X ⁽¹⁾
Parameters/ Configuration (4)			X	X	X	X	X	X	X	X
Protections			X	X			X		X	X
Trip history				X	X	X	X ⁽⁴⁾	X	X	X
General information			X	X	X	X	X	X	X	X

NOTES

- 1 Voltage, Power, Energy Counter, Power Factor, Frequency and peak factor measurements available
- 2 Readings of generic input 0/1 available
- 3 Voltage, Frequency and peak factor measurements available if accessory module VM210 is installed
- 4 Trip history reading available for relay versions /PD

2.3.1 Measuring

The measurements are displayed in absolute values (e.g.: Amperes for the current values, Volts for the voltage values). The reading of a nil or unavailable value (because it is too low) is indicated by: “...” or an empty space.

2.3.2 Parameters/Configuration

This section displays the relay's configuration parameters and information, including the size of the CB, the neutral setting, the version of the relay, the language, frequency setting, the rated voltage, the external contacts, etc.

The availability of information depends on the maximum performance of the relay, as indicated in the relative table. Scroll the menu to display the data of the DEFAULT version (this function is available with up to 7.5 SW versions of the PR010/T unit 7.5).

Use the **↑** and **↓** keys of ENTER to scroll the sections.

2.3.3 Protections

The parameters of the main relay protections are displayed in this section.

Use the **↑** and **↓** keys of ENTER to scroll the sections.

2.3.4 Trip history

This section contains the data stored during the last tripping action of the relay, such as the current readings, tripping protection and the total number of trips.

The PR223EF and PR223DS relays can store up to 20 historic data items. Use the **↑** and **↓** keys or ENTER to scroll the records.

2.3.5 General information

This section contains data such as the name of the relay, the SW release and the serial number.

2.4 Programming

The data that can be configured with the ACE relays are given in the table below.

	PR11	PR11/VF	PR112	PR113	PR212	PR212MP	PR222	PR222MP	PR223EF	PR223DS
PROGRAMMING										
Parameters/ Configuration (1)			X	X	X	X	X	X	X	X
Protections			X	X	X(2)	X(2)	X(2)	X(2)	X	X

NOTES

- 1 For PR010/T unit SW releases up to 7.5, the settings can also be programmed in the DEFAULT configuration in the operating mode and the test parameters in the DEFAULT configuration)
 - 2 The protection parameters can be programmed in the ELT configuration
-

2.4.1 Configurations

In this section, the user can enter the settings of many different parameters concerning the relay and circuit-breaker, such as the size of the CB, the frequency, the Neutral setting, the programmable contacts, the communication parameters, etc.

Use the **↑** and **↓** keys within the menu to position the cursor on the required parameter, then change the values of the parameters within the permitted range using the **←** and **→** keys. Once the changes have been made, press ESC to display the confirmation page.

2.4.1.1 *PR223DS: Current Measure Calibration*

The current readings in the PR223DS relay can be corrected in the manual mode by means of the calibration procedure.

The relay only accepts corrections for current values exceeding 0.05In. The maximum deviation in relation to the value read without calibration is 5%. Calibration can be reset by restoring the default configuration (the “Restore Default” command in the calibration menu).

2.4.1.2 *PR223EF: S51/P1 Contact configuration*

The option allowing the status of contact S51/P1 and the external contacts to be configured and read is available from relay release 3.01 onwards.

2.4.2 Protections

The settings are made by means of the same procedure used for programming the configuration parameters.

Different protections are available, depending on the model and version of the relay. Consult the manuals and catalogues of the individual values for a full description.

With PR223EF, the type of interlock for the IL protection (Driver), required for connection to relays of a different type, is available from release 3.01 onwards. Consult the manual of the unit for details.

3. SACE PR12x/PR232/PR33x/ PR12xDC protection relays

3.1 Mechanical connection

The relays of the following series:

- New Emax (PR121/P, PR122/P, PR123/P)
- Tmax T7-8/Emax X1 (PR232/P, PR232/P-T8, PR331/P, PR332/P, PR333/P)
- Emax DC (PR122DC, PR123DC)

are connected to PR010/T units with the same type of cable.

Use the supplied mechanical adapter to ensure a correct connection with relays of the Tmax T7-8/ Emax X1 series. The writing on the adapter of the connected device must point towards the device itself (the example shows how the adapter is assembled for a connection to PR332/P).

Auxiliary power is not required for use of the above mentioned relays with PR010/T units.

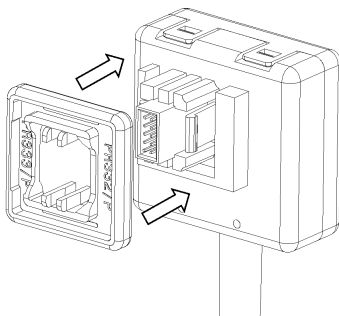

3.2 Operating mode menu

All the relays in the previous chapter share the same menu structure in PR010/T units. They also partly or fully share certain functions and characteristics.

Considering the main menus, all the units allow access to the following menus:

- *Test*: test of the protections, trip mechanism and high signals.
- *Measuring*: monitoring of the currents and other runtime values of the relay.
- *History*: historic reading of trips and other stored measurements.
- *Setting configuration*: modifies the characteristic parameters of the relay.
- *Protection configuration*: modifies the protection thresholds and parameters.
- *Information*: reading of the characteristic information of the CB unit and relay.
- *Status*: presence of alarms (if any).
- *Installation*: installation and disinstallation of a new relay in the CB.

3.3 Test

	PR121/P	PR122/P	PR123/P	PR331/P	PR332/P	PR333/P	PR232/P ⁽¹⁾	PR122DC	PR123DC
TEST									
Automatic	X	X	X	X	X	X	X	X	X
Manual	X	X	X	X	X	X	X	X	X
Trip Test	X	X	X	X	X	X	X	X	X
Module sign. ⁽²⁾		X	X	X	X	X		X	X
S and G selectivity ⁽³⁾		X	X		X	X		X	X
Rc ⁽⁴⁾		X	X		X	X			

NOTES

- 1 Relays PR232/P and PR232/P-T8 share the same settings and types of controls in PR010/T
- 2 The note refers to modules PR120/K (for relays PR122 and PR123), and contact S51/P1 (for relay PR33x)
- 3 Test only possible for relay versions with protections S and/or G
- 4 Test only possible if the Rc sensor is connected



CAUTION

The Test menu cannot be accessed if there is an alarm or if the circulating current is not nil.

3.3.1 Automatic Test

The automatic test must be performed with the circuit-breaker open. With certain relays, it may be impossible to access/run the test if the circuit-breaker is closed.

Various tests are available for each relay, regardless of the functional characteristics.

	PR121/P	PR122/P (2)	PR123/P	PR331/P	PR332/P (2)	PR333/P	PR232/P	PR122DC	PR123DC
AUTOMATIC TEST									
Three-phase currents	x	x	x	x	x	x	x		
Single-phase currents (1)	x	x	x	x	x	x			
Three-phase voltages		x	x		x	x			
Variable Phase Shift		x	x		x	x			
DC currents								x	x
DC voltage								x	x

NOTES

- 1 L1 is the phase subjected to single-phase testing
- 2 The Voltage and Phase Shift tests are only available for these relays when supplementary modules PR120/V or PR330/V are installed

The trip time settings of the relays during the tests will depend on the settings of the protections. The PR010/T unit will display the trip time and test result (OK; FAILED).

At the end of the test, the user is asked if he wishes to record a test report, which can then be downloaded into a PC.

Details of all the tests performed are given in the chapters dedicated to each individual relay, available from chapter 4.11 onwards.

3.3.2 Manual Test

The manual test must be performed with the circuit-breaker open. With certain relays, it may be impossible to access/run the test if the circuit-breaker is closed.

The manual test allows you to check the trip time of the relay with the required load condition. In detail, you can select the current value within the 0.00 to 16.00 In range, the voltage value within the 0.0 and 1.3 Vn range, the phase shift between -180° and +180° with 0.75° steps (if the relay allows voltages and phase shifts to be tested) and select one or more of the phases involved in the test (L1, L2, L3, Ne, Gte, V1, V2, V3). The phases chosen for the test are indicated by the “→” symbol.

The trip time settings of the relays during the tests will depend on the settings of the protections. The PR010/T unit will display the trip time and test result (OK; FAILED).

At the end of the test, the user is asked if he wishes to record a test report, which can then be downloaded into a PC.

3.3.3 Trip test

The trip test must be performed with the circuit-breaker closed.

This test allows a circuit-breaker opening command to be transmitted, thus checking the functionality of the opening system of the relay itself if tripping is caused by an overload or short-circuit.

3.3.4 Module Test

+24Vdc Auxiliary Power must be available for the Module Test.

During the contact module test (module PR120/K for PR12x series relays and contact S51/P1 for PR33x series relays), all the available contacts are momentarily excited (4 or 5 on module PR120/K and 1 for S51/P1). The user is responsible for checking the physical conditions.

Confirmation that the command has been transmitted is displayed by the PR010/T unit.

3.3.5 S and G selectivity

The zone selectivity tests can only be performed if an auxiliary power supply is available and with the circuit-breaker open.

The commands available in the unit excite the relay's zone selectivity outputs for the respective protections (S and G), thus allowing the wiring to be checked in the installations in which they are wired.

There is a dedicated command in the menu to release the stimulus on the outputs.

3.3.6 RC Test

This test allows a simulated signal to be transmitted to the RC sensor, the current of which, when read by the relay, causes the circuit-breaker to open, thus checking the residual current reading functionality.

3.4 Measuring

Various instantaneous measurements are available for each relay, regardless of the functional characteristics and versions.

Commands for resetting the energy meters and for the measuring history are also available for certain relays.

	PR121/P	PR112/P (1)	PR123/P	PR331/P	PR332/P (1)	PR333/P	PR232/P	PR122DC	PR123DC
MEASURING									
Currents	X	X	X	X	X	X	X	X	X
Peak factors	X	X	X	X	X	X			
Frequency		X	X		X	X			
Voltages, Power ratings, Energy values, Power Factors		X	X		X	X			X
Reset Energy command		X	X		X	X			X
Reset Measuring command		X	X		X	X			X

NOTES

- 1 Measures only available for these relays when supplementary modules PR120/V or PR330/V are installed

The reading of a nil or unavailable current (because it is too low) is indicated by: "...". When there are phase errors, the current is indicated by: "---".

Power measurements (Active, Reactive and Apparent) are available for both single channels and the whole (e.g.: P1, P2, P3, Pt). If the Neutral voltage is absent, the only measurement available is the total (e.g.: Pt).

Ig current is only available with the LSIG version of the relays. For the other versions, if indicated, it is represented by: "--".

3.5 Histories

Certain signals can be displayed for each relay, such as the history of the openings caused by the tripped protection, of the events, as well as certain statistical information about the relay openings.

	PR121/P (1)	PR122/P	PR123/P	PR331/P (1)	PR332/P	PR333/P	PR232/P	PR122DC	PR123DC
HISTORIES									
Trips (2)	X	X	X	X	X	X	X	X	X
Events (3)	X	X	X	X	X	X		X	X
Statistics (4)	X	X	X	X	X	X		X	X

NOTES

- 1 Do not store the number of total operations
- 2 Only the real trips are stored: the ones simulated during the test are not considered
- 3 Signals recorded only with Vaux or front battery units installed (with the exception of Contact Wear, which is also controlled with self-powered relays)

3.5.1 Trips

The information recorded for each Trip is displayed on two screen pages. All the trips can be consulted by scrolling the screen pages with the **↑** and **↓** keys.

Each trip has a progressive number and contains information about the protection that caused it, the date and time of the trip (with reference to the relay's internal clock), the contact wear status (CW) and the trip currents recorded.

3.5.2 Events

Each Event recorded includes a description, and the date and time at which it was recorded.

Events are displayed on two screen pages. The complete list of events can be consulted by scrolling the screen pages with the **↑** and **↓** keys.

3.5.3 Statistics

The statistics refer to: Contact Wear, Protection trip operations, Total operations, Manual operations, Failed trips, Trip Test trips.

Relays PR121/P and PR331/P do not store the number of Total Operations.

3.6 Configurations

The configurations and parameters of the relays can be displayed and modified.

	PR121/P	PR122/P	PR123/P	PR331/P	PR332/P	PR333/P	PR232/P	PR122DC	PR123DC
CONFIGURATIONS									
Circuit-breaker	X	X	X	X	X	X	X	X	X
HW trip	X	X	X	X	X	X	X	X	X
Alive LED	X			X					
Frequency	X	X	X	X	X	X			
Measurement storage period		X	X		X	X		X	X
Local Bus threshold		X	X		X	X		X	X
Startup current threshold		X	X		X	X		X	X
Dual Set			X			X			X
Harmonic distortion		X	X		X	X		X	X
Datalogger		X	X		X	X		X	X
Modules		X	X		X	X		X	X
Local Bus unit	X	X	X	X	X	X		X	X
System		X	X		X	X		X	X

The parameters can be changed by means of a procedure using the keypad:

- First choose the parameter/s that need to be changed. A page with a list of the current settings will appear on the display.
- A cursor will automatically set to the first parameter but the **↑** and **↓** keys can be used to move it within the page/s and to select other parameters.
- Having selected the parameter on the screen page, press ENTER to access the editing mode (the cursor will flash). Now use the **←** and **→** keys to change the value of the parameters within the permitted range.
- The editing work ends by confirming the changes with ENTER and pressing ESC until a saving window appears (where the operation must be confirmed). The new parameters/data will become operative in the relay after they have been saved.
- The keypad must be used for parameters that require alphanumeric characters (e.g.: CB TAG NAME).

- Press the corresponding key to enter numbers whereas, to enter a letter, first press the CAPS key (↑) and then the corresponding key as many times as the position of the letter on the key itself, like a mobile phone.



CAUTION

With PR121/P, PR331/P and PR232/P relays, certain parameters can only be changed with the dip switches on the front.

3.6.1 Circuit-breaker

Different parameters can be accessed in the Circuit-breaker menu.

	PR121/P	PR122/P	PR123/P	PR331/P	PR332/P	PR333/P	PR232/P	PR122DC	PR123DC
CIRCUIT-BREAKER									
Neutral	X	X	X	X	X	X	X		
Plant Configuration	X	X	X	X	X	X			
CB TAG NAME	X	X	X	X	X	X	X	X	X
User Data	X	X	X	X	X	X	X	X	X
Toroid (1)		X	X		X	X			

NOTES

- 1 The toroid can only be configured if it is present and connected to the unit

3.6.2 Alive LED

The relay status is signalled by the front LEDs in PR121/P and PR331/P units. The “Alive LED”c, or the signal that the relay is operating in conditions free from alarms or faults, can be enabled/disabled with PR010/T. The Alive LED signal corresponds to a flash from the pre-alarm led every 3 seconds.

The Default relay setting with Alive LED= ON.

Alive LED configuration is available for units with 2.05 or more recent SW releases.

3.6.3 Modules

Each Module has different denominations for each individual family. Consult the User Manual of the relay for further explanations and details.

	PR121/P	PR122/P	PR123/P	PR331/P	PR332/P	PR333/P	PR232/P	PR122DC	PR123DC
MODULES									
Measuring (1)		X	X		X	X			X
Communication (1)		X	X		X	X		X	X
Signalling (1) (2)		X	X		X	X		X	X

NOTES

- 1 The menus of the individual modules can only be accessed if they are physically present and connected to the relay
- 2 The module is understood as being the sole S51/P1 contact for relays of the PR33x series

3.6.3.1 Signalling Module

The Signalling module provides one or more programmable contacts (Relays).

The activation event/signal is displayed in the menu of each contact. Press ENTER to access the editing mode (the cursor starts flashing). Use the ← and → keys to change the setting of the activation signal.

Press ENTER to display the current setting for “Custom” selections. Events with an arrow (→) alongside indicate which elements are selected.

Use the ↑ and ↓ keys to display the previous/next screen page and activate/deactivate the selected elements with the ← and → keys (the arrow alongside the element is either displayed or removed).

There are 18 blocks, each of which is formed by eight elements displayed in three consecutive screen pages. Up to 8 elements can be activated per block.

The AND/OR logic applied to the selected elements and the minimum relay activation time can be defined in the last screen page of each block.

3.6.4 Local Bus unit

The Local Bus unit is similar to the Signalling module (it provides several open/close contacts: 7 at most) but also allows the presence of the actual unit to be selected/deselected:

Select “Present” to select the presence/absence of a unit on the local bus: if no unit is physically connected, the relay will signal the correlated alarm. The Local Bus unit is available for all the relays, with the exception of PR232/P.

3.6.5 System

Additional data, such as the date/time and language setting can be entered for certain relays. This option is available for all the relays except PR121/P, PR331/P e PR232/P.

3.7 Parameters

The parameters of the relay protections can be displayed and changed.

The availability of some of the protections depends on the relay version:

1. protections S, G and Gext are not available for the LI versions;
2. protections G and Gext are not available for the LSI versions.

	PR121/P	PR122/P (1)	PR123/P	PR331/P	PR332/P (1)	PR333/P	PR232/P	PR122DC	PR123DC
PARAMETERS									
L	X	X	X	X	X	X	X	X	X
I	X	X	X	X	X	X	X	X	X
S	X	X	X	X	X	X	X	X	X
S2			X			X			X
D			X			X			
G	X	X	X	X	X	X			X
Gext (2)		X	X		X	X			
U		X	X		X	X			X
T		X	X		X	X		X	X
LC1		X	X		X	X		X	X
LC2		X	X		X	X		X	X
Iw		X	X		X	X		X	X
Rc (2)		X	X		X	X			
MCR		X	X			X		X	X
UV (3)		X	X		X	X			X
OV		X	X		X	X			X
RV		X	X		X	X			
RP		X	X		X	X			X
UF		X	X		X	X			
OF		X	X		X	X			

NOTES

- 1 UV, OV, RV, RP, UF, OF protections only available when the Measuring module is installed and with versions LSI and LSIG
 - 2 Only available for LSIG versions and when the correlated sensor is installed
 - 3 Only available when the residual current sensor (Rc) is not installed
-

The editing/saving modes for the protection parameters is the same as the one described previously for the other configuration parameters.



CAUTION

The protection settings cannot be changed if the relay is in the overcurrent Alarm or Pre-Alarm status.

3.7.1 Limitations

There are limitations to the display/editing modes of some of the protections for relays of the PR12x series, regardless of the SW release.

- The following limitations must be considered for PR121/P relays with software releases prior to 1.10:

1. Startup time protection S:	$0.1s \leq \text{Time} \leq 1.5s$ step 0.01s
2. Startup time protection G:	$0.1s \leq \text{Time} \leq 1.5s$ step 0.01s
3. Startup current activation threshold	not available
4. Control of unit contacts on local bus	not available

- The following limitations must be considered for PR122/P relays with software releases prior to 1.10:

1. Startup time protection S:	$0.1s \leq \text{Time} \leq 1.5s$ step 0.01s
2. Startup time protection G:	$0.1s \leq \text{Time} \leq 1.5s$ step 0.01s
3. Startup time protection Gext:	$0.1s \leq \text{Time} \leq 1.5s$ step 0.01s
4. Startup current activation threshold	not available
5. Threshold protection U:	$5\% \leq \text{th} \leq 90\%$ step 5%
6. Control of unit contacts on local bus	not available

- The following limitations must be considered for PR123/P relays with software releases prior to 1.10:

1. Startup time protection S:	$0.1s \leq \text{Time} \leq 1.5s$ step 0.01s
2. Startup time protection S2:	$0.1s \leq \text{Time} \leq 1.5s$ step 0.01s
3. Startup time protection G:	$0.1s \leq \text{Time} \leq 1.5s$ step 0.01s
4. Startup time protection Gext:	$0.1s \leq \text{Time} \leq 1.5s$ step 0.01s
5. Startup time protection D:	$0.1s \leq \text{Time} \leq 1.5s$ step 0.01s
6. Startup current activation threshold	not available
7. Threshold protection U:	$5\% \leq \text{th} \leq 90\%$ step 5%
8. Minimum custom datalogger enabling time	not available

3.8 Information

This menu displays information about the relay and circuit-breaker.

The menu can also be accessed so as to download information from the PR010/T unit to the PC. The download requires a dedicated procedure. It is not available for PR232/P.

3.8.1 Download

A file is created containing a first group of information, stored in the non-volatile memory of the PR010/T unit. You will be asked to enter certain information for heading the report, namely the date, time, operator's name and CB Serial Number.

This file can be downloaded into a PC in the same way as the normal test reports are downloaded.

The Download info 2 command can also be used to download a group of useful information.

Vacant space must be created in the memory before the data are stored and downloaded into the PC.

Only one group of information can be stored at a time by freeing space (deleting reports) before storing another group. For example, if you wish to download all the information (download info 1 and download info 2):

- Delete any reports to free sufficient space in the non-volatile memory
- Perform download 1
- Download the corresponding file into the PC
- Delete reports
- Perform download 2
- Download the corresponding file into the PC
- Delete reports to free sufficient space for the report of a next test

3.9 Status

This menu allows you to display configuration/wiring error signals of the protection unit and circuit-breaker concerning:

- The status of the 3 current reading sensors (L1, L2, L3, Ne, Gtext)
- The status of the mechanical release (TC)
- The status of the rated current detector applied to the front (Rating Plug)
- Installation error
- Internal error of the device
- Date error
- Parameters/protections Configuration error
- Circuit-breaker (CB) error

Refer to the user manual of the relay for instructions about how to resolve the errors.

3.10 Installation

This menu describes the installation and disinstallation commands, of use if certain information must be exchanged between the circuit-breaker and relay, when this latter is replaced.

3.10.1 Disinstallation

The disinstallation procedure is not strictly necessary, but it allows the circuit-breaker parameters, such as contact wear and others that would otherwise be lost, to be stored.

The operation is performed on the relay that must be removed and replaced, while it is still assembled on the circuit-breaker and with this latter open.

After disinstallation, the part can be replaced and successively installed.

3.10.2 Installation

The operation is performed on the new unit that must be installed, after it has been assembled and wired and with the circuit-breaker open.

If both operations are performed correctly, the user returns to the main menu and will have to repeat the relay log-in.



CAUTION

For both operations, when the following screen page appears: "Switch off relay" means: "remove any Vaux present".

```
Install/Disinstall
done
Switch off relay
and press ENTER
```

3.11 Automatic Test: full description

Details of the automatic tests performed on the individual electronic relays are described below.

The result and length of the protection tests depends on the thresholds and values entered by the user.

3.11.1 PR121/P, PR331/P; PR122/P and PR332/P without measuring module

Test N°	Phase			Value
	L1	L2	L3	
1	■	■	■	0.3 In
2	■	■	■	3.0 In
3	■	■	■	5.0 In
4	■	■	■	10.0 In
5	■	■	■	15.0 In
6	■			0.3 In
7	■			3.0 In

3.11.2 PR122/P and PR332/P (with measuring module)

Test N°	Phase						Amplitude		Phase Shift
	L1	L2	L3	V12	V23	V31	I [In]	V[Un]	Φ
1	■	■	■	■	■	■	3.0	1.0	30°
2	■	■	■	■	■	■	5.0		
3	■	■	■	■	■	■	10		
4	■	■	■	■	■	■	15		
5	■			■	■	■	0.3	1.0	0°
6	■			■	■	■	3.0		
7	■	■	■	■	■	■	0.3	1.0	210°
8	■	■	■	■	■	■	3.0		
9	■	■	■	■	■	■	5.0		
10	■	■	■	■	■	■	10		
11	■	■	■	■	■	■	15		
12				■	■	■	0.0	0.4	---
13				■	■	■		1.3	

3.11.3 PR123/P and PR333/P

Test N°	Phase						Amplitude		Phase Shift
	L1	L2	L3	V12	V23	V31	I [In]	V[Un]	Φ
1	■	■	■	■	■	■	3.0	1	30°
2	■	■	■	■	■	■	5.0		
3	■	■	■	■	■	■	10		
4	■	■	■	■	■	■	15		
5	■			■	■	■	0.3	1	0°
6	■			■	■	■	3		
7	■	■	■	■	■	■	0.3	1	210°
8	■	■	■	■	■	■	3		
9	■	■	■	■	■	■	5		
10	■	■	■	■	■	■	10		
11	■	■	■	■	■	■	15		
12				■	■	■	0.0	0.4	
13				■	■	■		1.3	

3.11.4 PR232/P and PR232/P-T8

Test N°	Phase			Value
	L1	L2	L3	
1	■	■	■	0.5 In
2	■	■	■	3.0 In
3	■	■	■	5.0 In
4	■	■	■	8.0 In
5	■	■	■	12.0 In

3.11.5 PR122/DC

Test N°	Amplitude	
	I [In]	V[Un]
1	3.0	1
2	5.0	1
3	10	1

3.11.6 PR123/DC

Test N°	Amplitude	
	I [In]	V[Un]
1	3.0	1
2	5.0	1
3	10	1
4	0.3	1
5	3	1
6	0	0.4
7	0	1.3
8	-0.4	1
9	-3	1
10	-5	1
11	-10	1